

2017-12-14, Martin (Slovakia)

3rd Final Conference of FUTURA project



The FUTURA project has received funding from the European Union's Horizon 2020 research and innovation programme under grant agreement No 700985.

Agenda:

- ⦿ 11:00 – 11:15 Welcome speech of the project manager
- ⦿ 11:15 – 11:30 Presentation of project partners
- ⦿ 11:30 – 12:00 Presentation of the FUTURA project and results
- ⦿ 12:00 – 12:30 Press conference
- ⦿ 12:30 – 13:15 Discussion
- ⦿ 13:15 – 13:30 Snacks and coffee



The FUTURA project has received funding from the European Union's Horizon 2020 research and innovation programme under grant agreement No 700985.

FUTURA

„FUTURE RAIL freight transport:

Cost-effective, safe, quiet and green



The FUTURA project has received funding from the European Union's Horizon 2020 research and innovation programme under grant agreement No 700985.

FUTURA

project will focus on the final steps of development of new generation of axle mounted **Divided Rail Freight Brake (DRFB)** disc.

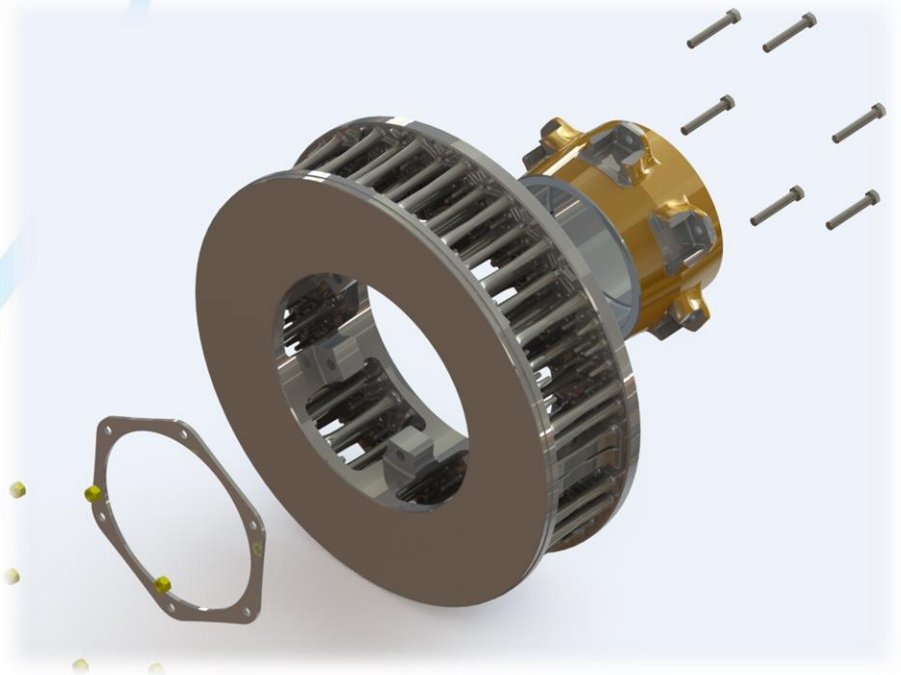
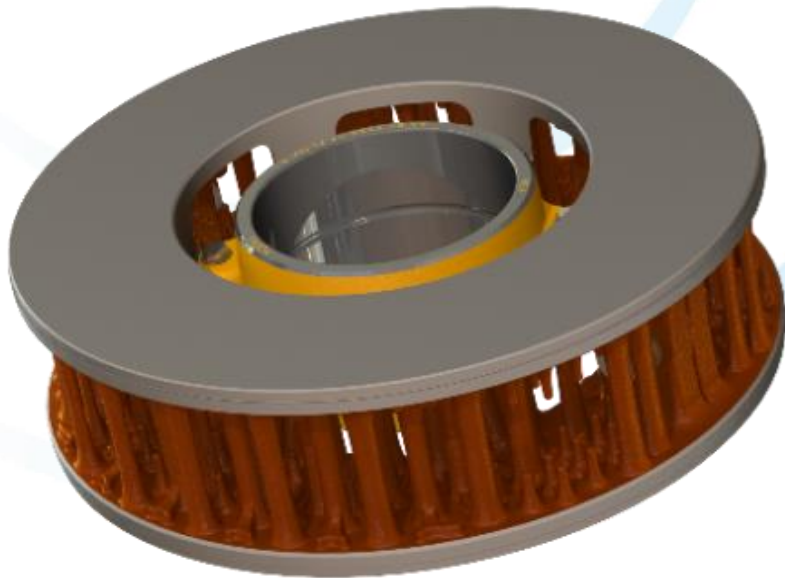

FUTURA

- ④ The FUTURA project is an answer to all challenges in Horizon 2020 call Fast Track to Innovation Pilot (FTIPilot-1-2015).
- ④ This call targets relatively mature new technologies, concepts, processes and business models that need a last development step to reach the market and achieve wider deployment.



The FUTURA project has received funding from the European Union's Horizon 2020 research and innovation programme under grant agreement No 700985.

MAIN OBJECTIVE

- ④ The main objective of the FUTURA project is to improve the quality and safety of life of over 55 million EU citizens who live or work near train tracks.
- ④ With its innovative solution, FUTURA project will influence the following 3 key elements:
 - Safety and Security
 - Health and Environment
 - Cost-effectiveness in rail freight transport (RFT)



The FUTURA project has received funding from the European Union's Horizon 2020 research and innovation programme under grant agreement No 700985.

SPECIFIC OBJECTIVES

- ⦿ Enable higher speeds in RFT (160 km/h)
- ⦿ 11% shorter braking distance and higher safety
- ⦿ 11% greater efficiency through 15% better heat dissipation and 14% less vibrations
- ⦿ 21% lower mass
- ⦿ 10 dB lower noise
- ⦿ 60% lower maintenance costs
- ⦿ 13% lower LCC

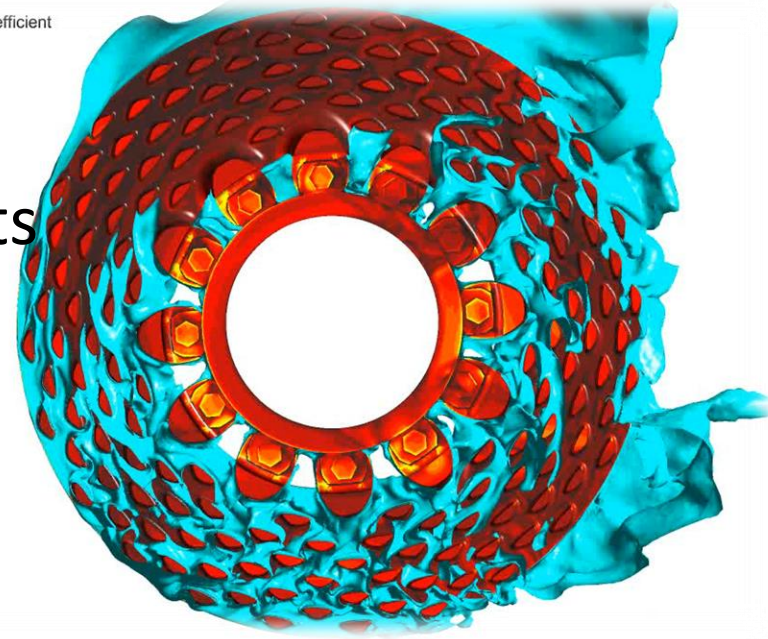

EXPECTED IMPACTS OF FUTURA PROJECT

- ⦿ A significantly higher safety and security in RFT
- ⦿ Improving cost-effectiveness of rail transport
- ⦿ Reduced level of noise
- ⦿ Positive environmental impact
- ⦿ Increase of private sector's investments and innovation activities

EXPECTED BENEFITS

- ④ Total available market size around 12 billion € per year
- ④ Key target markets:
EU, USA, Canada, Russia, China, India and Brazil
- ④ Capture 7% of the market share in the production of brake discs for RFT



The FUTURA project has received funding from the European Union's Horizon 2020 research and innovation programme under grant agreement No 700985.

CONSORTIUM

- 4 partners from 3 different countries:

KOVIS



OMNIA KLF



ZX-BENET

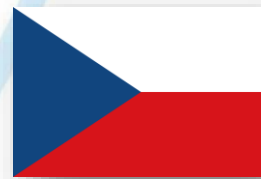

VUD



PROJECT RESULTS

① Two final prototypes of DRFB disc:

① 170mm of width

① 110mm of width

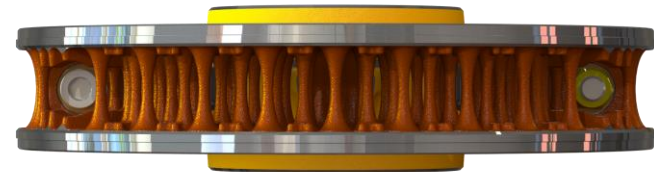
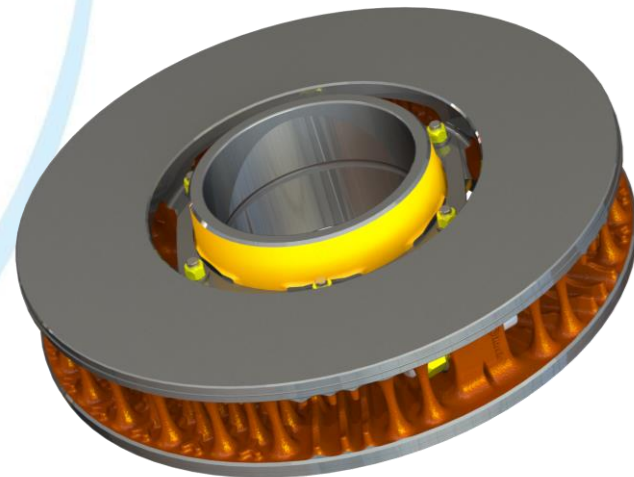
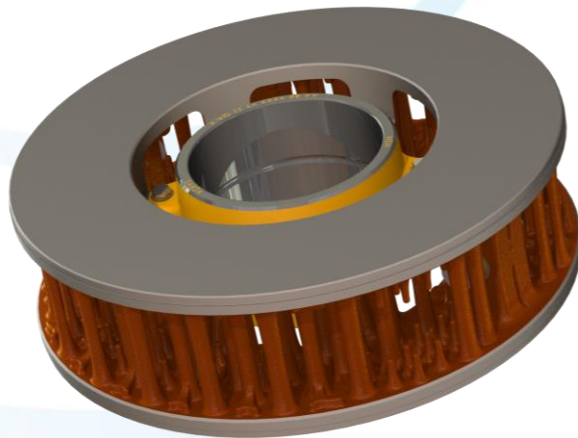

PROJECT RESULTS

🎯 Suitable for higher speeds in RFT (160 km/h)

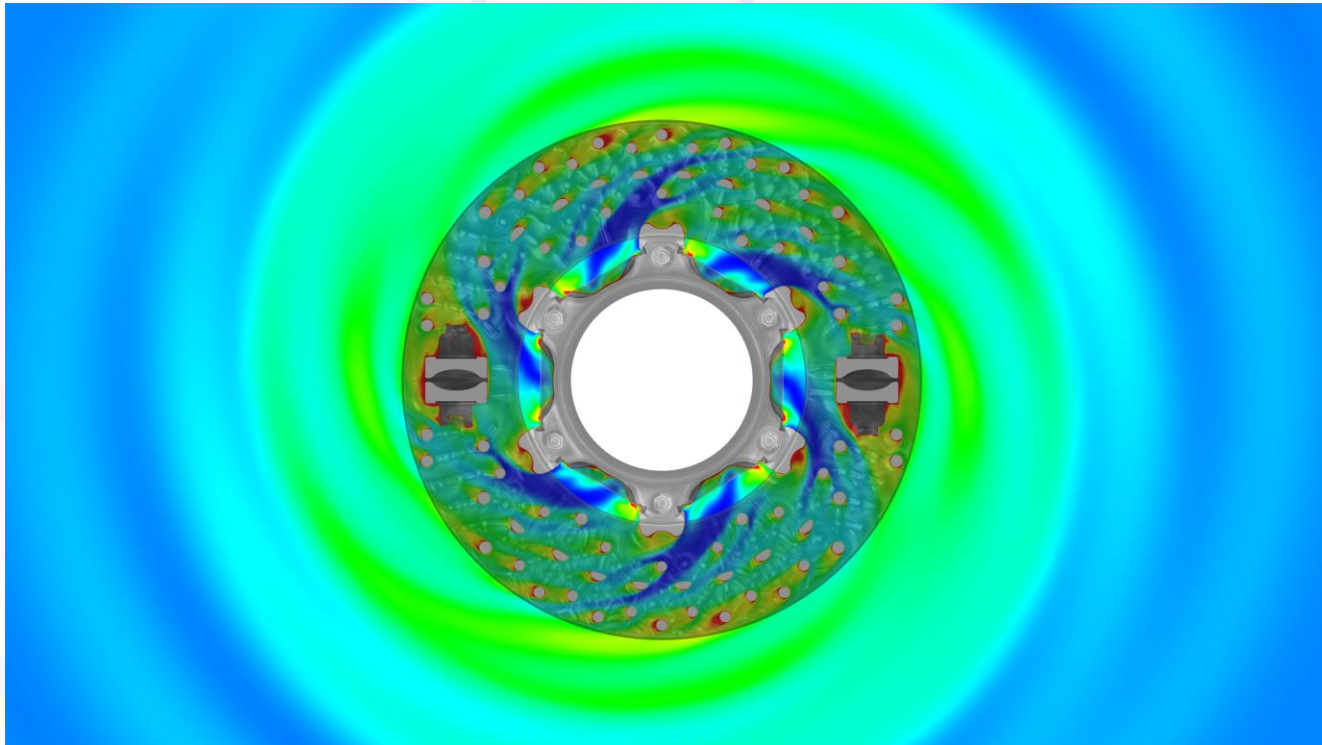

PROJECT RESULTS

🎯 22,7% lower mass for 590x170mm disc

🎯 34,5% lower mass for 590x110mm disc

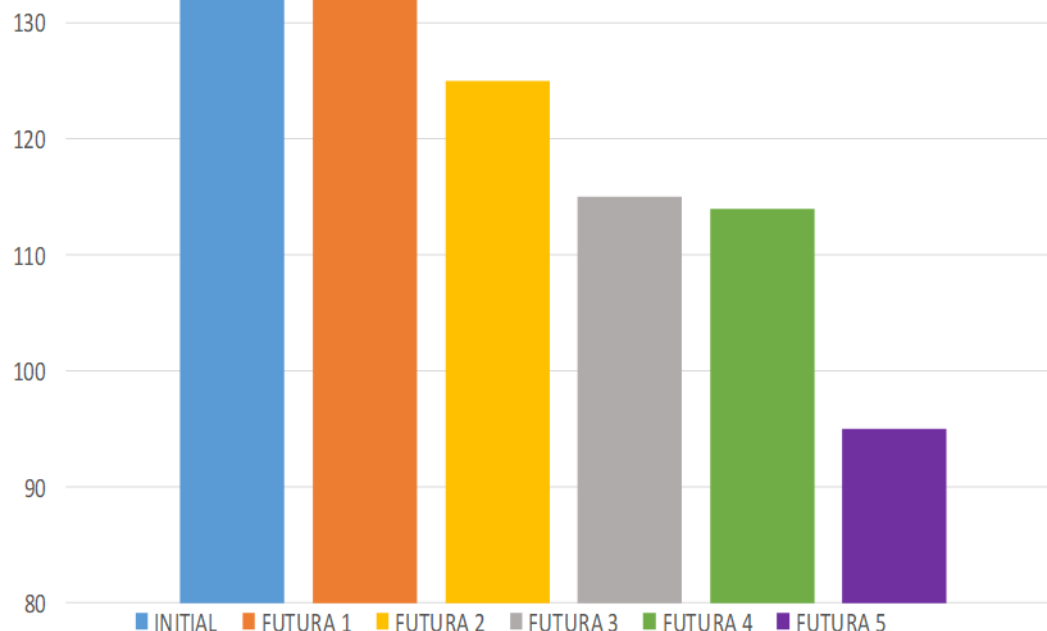

The FUTURA project has received funding from the European Union's Horizon 2020 research and innovation programme under grant agreement No 700985.

PROJECT RESULTS

- ① 11% shorter braking distance and higher safety due to special patented brake plate-hub connection
- ② 15% less vibrations due to special patented brake plate-hub connection

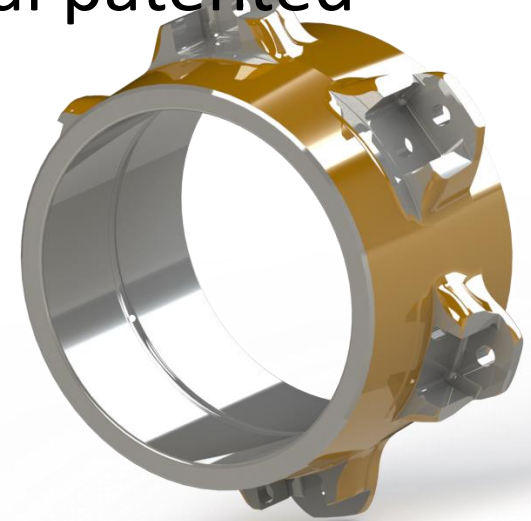
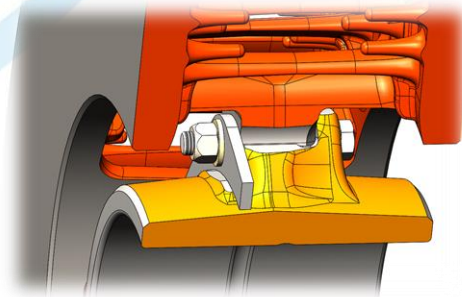
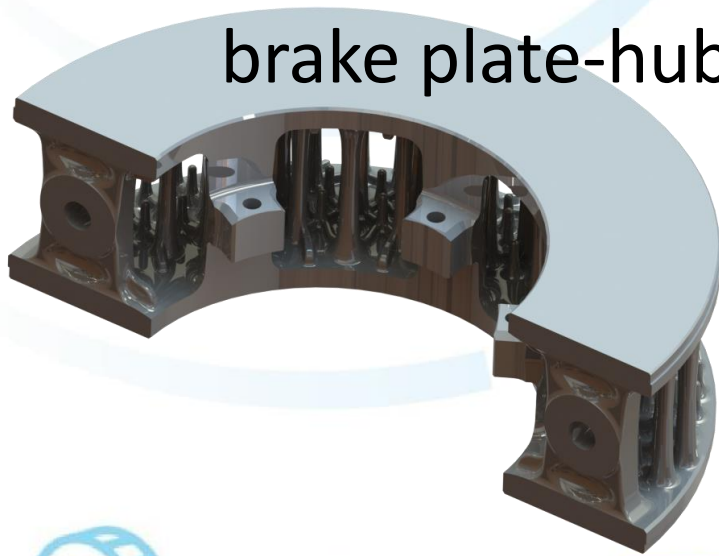

PROJECT RESULTS

🎯 11% greater efficiency through 15% better heat dissipation

CB: 40s futura 4 LD
Temperature
Type: Temperature (Average Across Bodies)
Unit: °C
Time: 25
Custom Obsolete
Max: 373
Min: 25.055
3.5.2017 12:14

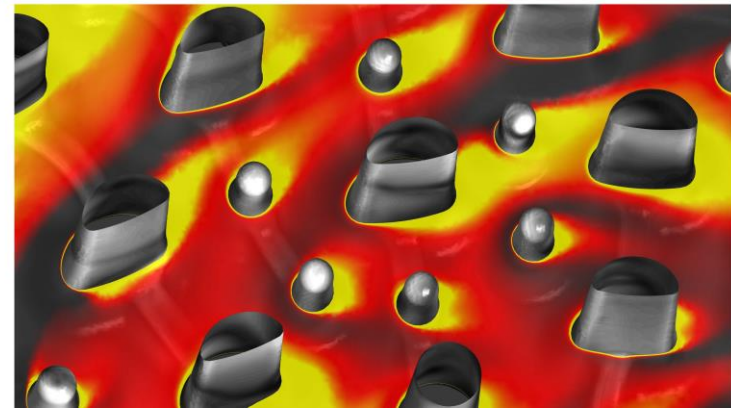
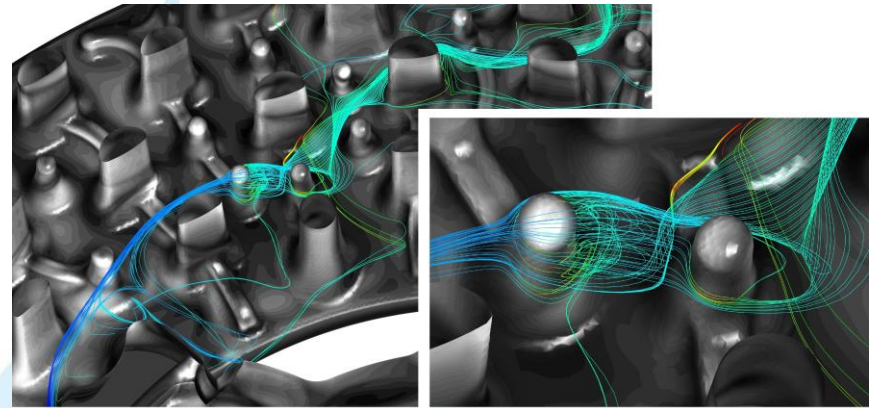
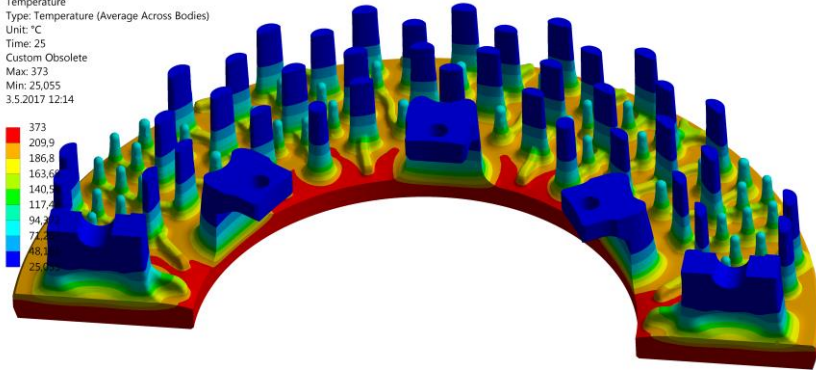

PROJECT RESULTS

11MJ Emergency brake temperatures

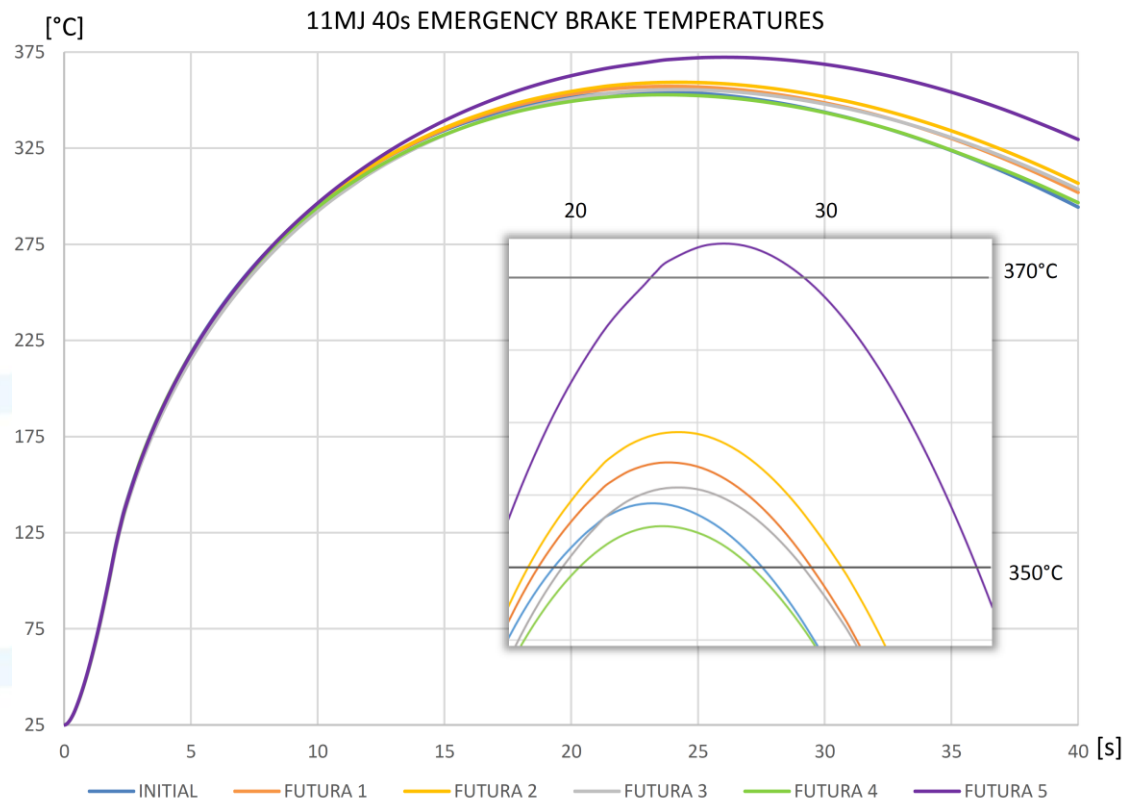

PROJECT RESULTS

🌀 Ventilation losses (Air resistance)

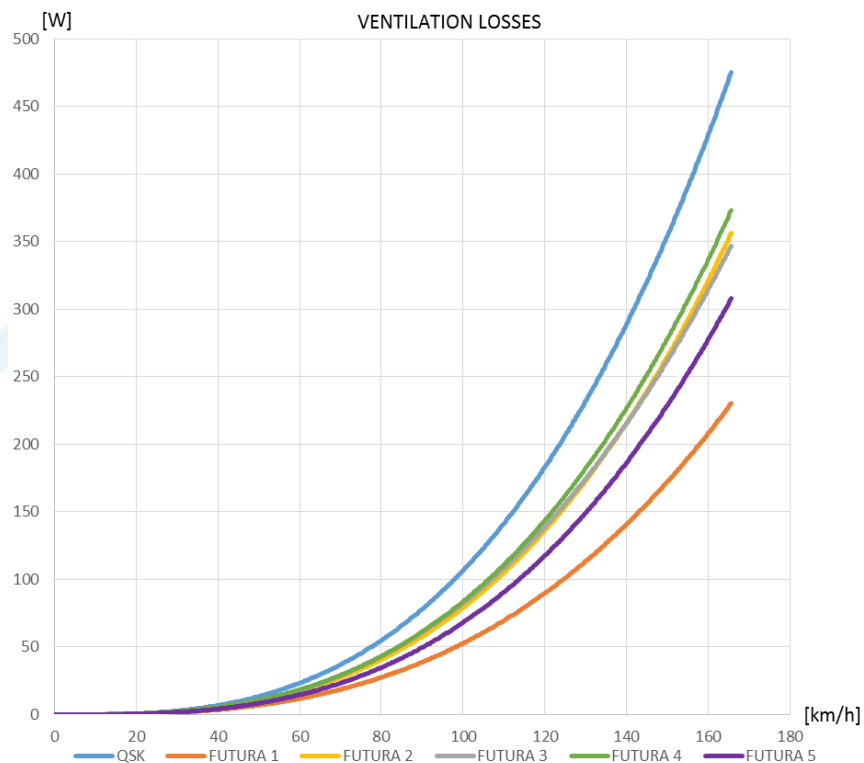

PROJECT RESULTS

- ① 10 dB lower braking noise in real environment test in comparison to K-block
- ① 6 dB lower noise level of unbraked disc 590x170 (4 dB for 590x110)



PROJECT RESULTS

- 60% lower maintenance costs due to divided version and simple mounting procedure

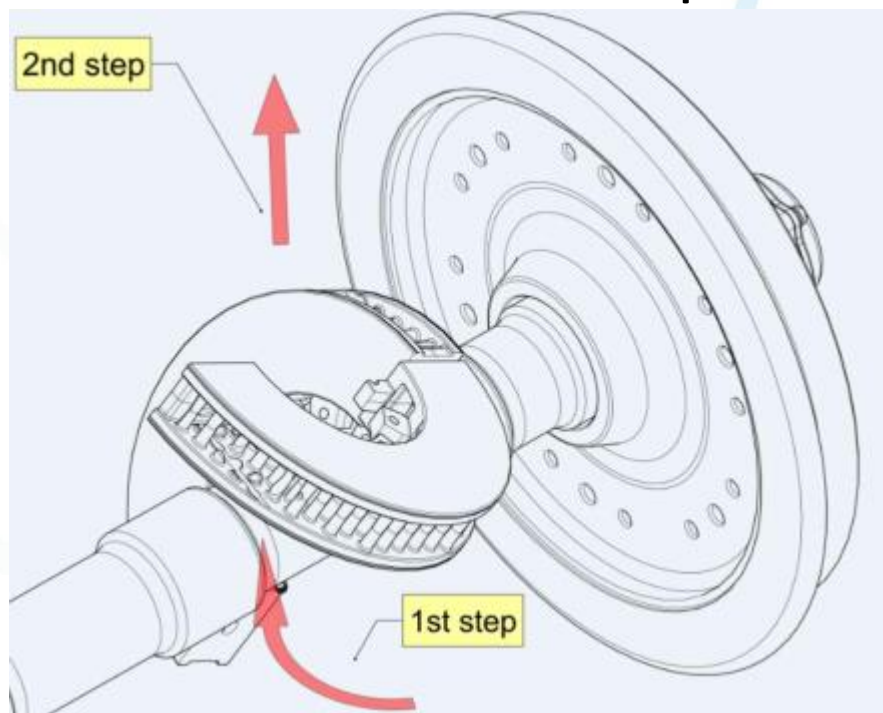

PROJECT RESULTS

🎯 20% lower LCC of DRFB disc



The FUTURA project has received funding from the European Union's Horizon 2020 research and innovation programme under grant agreement No 700985.

PROJECT RESULTS

Successfully passed tests:

- ① Test program B.1 (Freight wagons, Energy class A1, UIC 541-3, 8th Edition)



- ① Tests according TSI for freight wagons (COMMISSION REGULATION (EU) No 321/2013)

PROJECT RESULTS

- ① 1,800 000 – 2,600 000 km – Average predicted lifetime of DRFB disc



FUTURA ON WEB

<http://www.projectfutura.com>

FUTURA ON FACEBOOK

<https://www.facebook.com/projectfutura>



Like us on
Facebook



FUTURA



The FUTURA project has received funding from the European Union's Horizon 2020 research and innovation programme under grant agreement No 700985.

THANK YOU !



The FUTURA project has received funding from the European Union's Horizon 2020 research and innovation programme under grant agreement No 700985.